

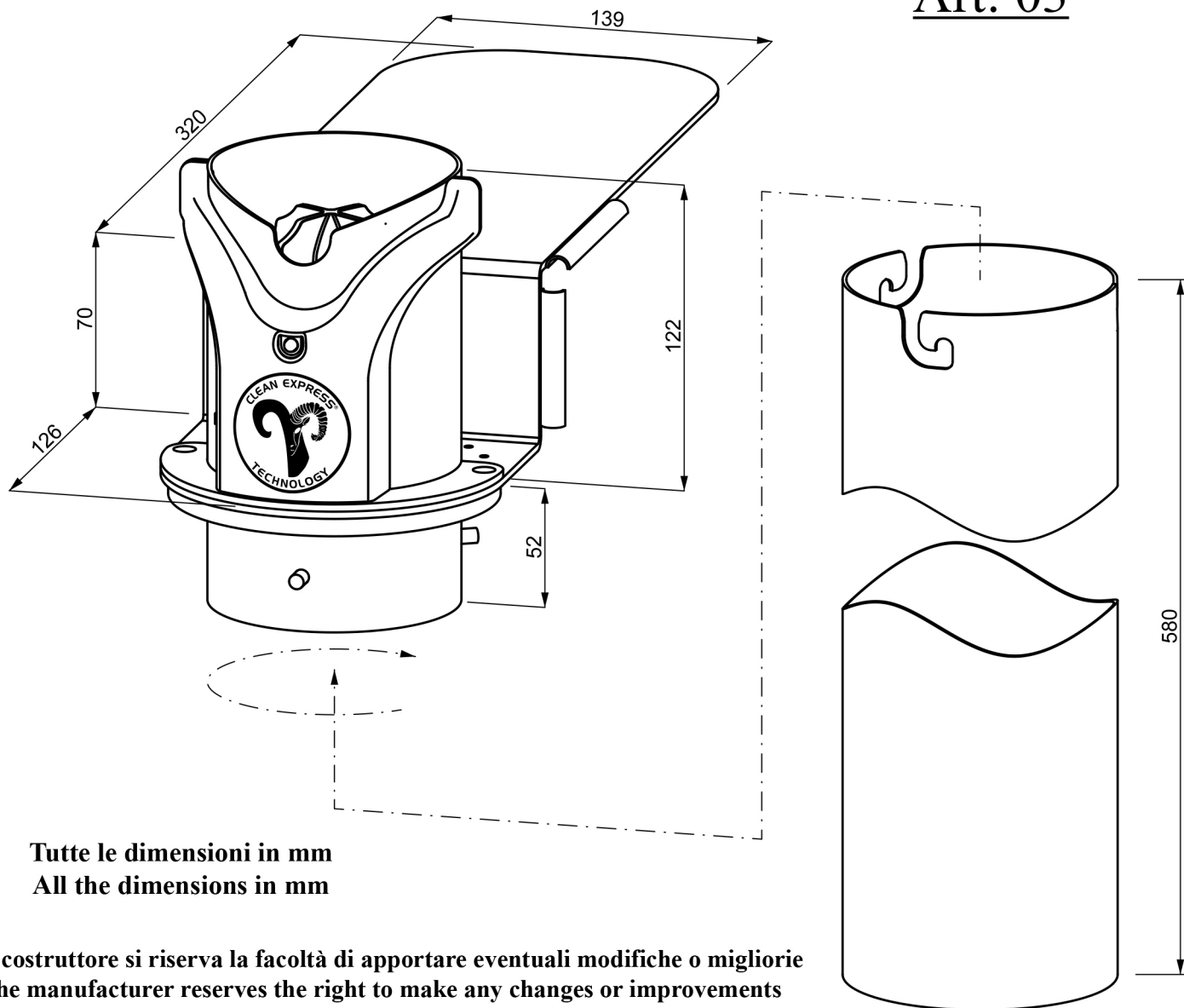

CLEAN EXPRESS® TECHNOLOGY

Scheda Tecnica - Technical Data
Versione con tubo esterno - External tube version

Art: 03



Tutte le dimensioni in mm
All the dimensions in mm

Il costruttore si riserva la facoltà di apportare eventuali modifiche o migliorie
The manufacturer reserves the right to make any changes or improvements

Alimentazione - Supply: 220V - 12V; 5A; 50-60 HZ

Peso - Weight: kg 6,5

Dimensioni Imballo - Package Dimension: cm. 60X40X20

Garanzia - Warranty: 12 mesi - months



CLEAN EXPRESS TECHNOLOGY di Cadamuro Francesca

Via Monte Grappa, 7/A - 31017 PADERNO DEL GRAPPA (TV)

Cod. Fisc. CDMFNC92H65A703G - P. I.v.a. 04792630263 - R.E.A. 378330

+39 347 1911391 - cleanexpresstechnology@yahoo.com

[Facebook: Clean Express Technology](#)